

# ATOM STEEL

WE CONSTRUCT PERFECT  
METAL COMPONENTS  
FOR THE BEST COMPANIES  
IN THE WORLD

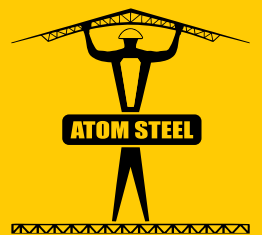

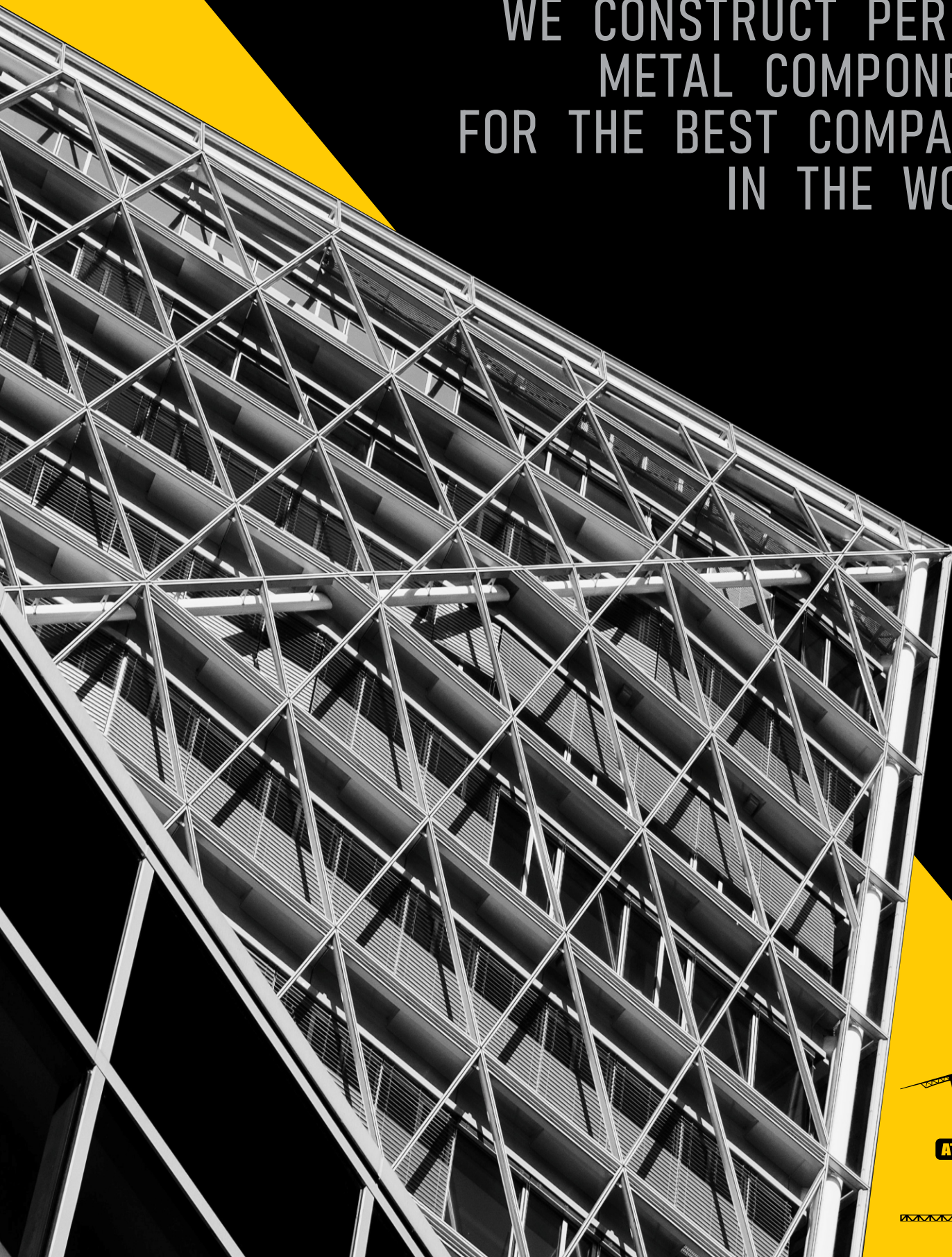

# ATOM STEEL OVERVIEW







# ATOM STEEL OVERVIEW

With 60 years of experience and knowledge of international standards, technological changes and industrial systems, we are dedicated to provide the best and economical solutions to our valued customers.

We have facility to produce advance various industrial steel products based on specially developed technology. We are also ready to development by according to users changing needs. The solutions we develop are innovative, practical, technically sound and economical as possible, in both time and money. Atom Steel LTD offers wider range of special consulting engineering's and design services for constructability.

We offer these services to owners, engineers and contractors by applying with 60 years of knowledge and experience in civil and structural engineering. Innovative new ideas are integrated into planning, design, procurement and field operations to achieve overall projects objective.



# ATOM STEEL HISTORY







## ATOM STEEL HISTORY

The beginning of ATOM dates back to 1960/1961, then ATSH (Autotransport and forwarding), and its creator was Dushko... The initial activity was transport and forwarding. It was a small company with a few vehicles and a small number of people. It is located on the present site of the Pavlina Veljanova Kindergarten in barracks. With the publication of Todosia Paunov in 1968, they moved to the current location of ATOM and its expansion began. Buildings, a gas station and the biggest administrative building in Kocani at that time began to be built. The total fleet, with buses and trucks, recognizable as blue swallows throughout Yugoslavia, where there were over 120 trucks. It was renamed ATOM (Autotransport, organization and mechanization), and with that the activity expanded with carpentry, locksmith and other plants, where it expanded its work to the Middle East, Iraq and Iran. The administrative building was completed in 1975/1976 and then there were over 1000 people. 1978-1988 ATOM Kocani was established in 1978, as a state enterprise, where it works with the production of metal halls, reservoirs, metal beams for bridges, etc.

Atom is privatized and divided into several companies. On June 26 2013, Atom concluded ATOM STEEL LTD

# MANUFACTURING ACTIVITES





# MANUFACTURING ACTIVITIES

Atom Steel LTD offers wider range of special consulting engineering's and design services for constructability. We offer these services to owners,engineers and contractors by applying over 60 years of knowledge and experience in civil and structural engineering. Innovative new ideas are integrated into planning, design, procurement and field operations to achieve overall projects objective.

The total surface of the section for work with metals is 25.000m<sup>2</sup> of which 20.000m<sup>2</sup> is the surface of the hall.





# MANUFACTURING ACTIVITES









**POLE  
PRODUCTION**





# POLE PRODUCTION



Polygonal Poles, Highway Poles, Road and Street Lighting Poles.

All kind of pole production capability from 3 m up to 120 m with special design, wind, engineering and static calculations. Environmental friendly and CE Approved pole manufacturing.

Slipjoint and inner-flanged connection systems.

Specially designed lighting pole production with one, two or three body options. Polygon poles can be produced as your wish up to your projects.

Our team is ready for pole production.

Rotational or fixed pulley systems.



**POLE  
PRODUCTION**





# POLE PRODUCTION



# ROUND CONICAL POLES





# ROUND CONICAL POLES

Round Conical Poles, distinguished by their sleek and tapered design, exemplify a pinnacle of engineering precision in the world of infrastructure solutions. At Atom Poles, these poles undergo a meticulous manufacturing process, beginning with the careful selection of high-grade hot-rolled steel coils to establish a foundation of durability and resilience.

The automated production procedure involves a sophisticated interplay of cutting and folding or pressing the trapezoidal sheet into the elegant conical shape that characterizes these poles. This process, executed with precision, not only ensures uniformity but also guarantees structural integrity, allowing Round Conical Poles to seamlessly integrate into a variety of infrastructure applications.

A key feature of our production methodology is the application of longitudinal welding through the submerged arc welding technique. This process welds the sides of the conical shape seamlessly, enhancing the overall structural stability and longevity of the poles. The use of submerged arc welding ensures a robust and enduring connection, capable of withstanding environmental stresses and contributing to the reliability of the infrastructure.

Atom Poles takes pride in delivering Round Conical Poles that not only meet but exceed industry standards. These poles find versatile applications, ranging from highway and street lighting to traffic signage, electrical distribution, and transmission towers. Additionally, they serve in wireless communication towers, high mast and sport lighting poles, transit poles, solar lighting, and wind tower poles.

Our commitment extends beyond mere functionality. Atom Poles offers a diverse range of Round Conical Poles that not only fulfil practical purposes but also contribute to the aesthetic appeal of urban landscapes. Whether it's the precision in design or the durability in construction, our Round Conical Poles embody the fusion of engineering excellence and a steadfast commitment to quality that defines Atom Poles in the realm of infrastructure solutions.

# ROUND CONICAL POLES

## CONICAL LIGHT POLE PRESS BRAKE TOOL SPECIFICATION

tool length 16 m ; taper rate: 11 / 1000 ; small end OD: 60 mm ; Big end OD: 236 mm ; bascial thickness: 3-4 mm

It can do the following size CONICAL CIRCULAR light pole.

Light pole length,small end outer diameter,big end outer diameter table

small end OD (mm)	60	70	80	90	100	110	120	130	140	150	160	170	180	190	200	210
pole length (m)	Big end outer diameter table (mm)															
2	82	92	102	112	122	132	142	152	162	172	182	192	202	212	222	232
3	93	103	113	123	133	143	153	163	173	183	193	203	213	223	233	
4	104	114	124	134	144	154	164	174	184	194	204	214	224	234		
5	115	125	135	145	155	165	175	185	195	205	215	225	235			
6	126	136	146	156	166	176	186	196	206	216	226	236				
7	137	147	157	167	177	187	197	207	217	227						
8	148	158	168	178	188	198	208	218	228							
9	159	169	179	189	199	209	219	229								
10	170	180	190	200	210	220	230									
11	181	191	201	211	221	231										
12	192	202	212	222	232											

tool length 16 m ; taper rate: 13 / 1000 ; small end OD: 60 mm ; Big end OD: 268 mm ; bascial thickness: 3-4 mm

It can do the following size CONICAL CIRCULAR light pole.

Light pole length,small end outer diameter,big end outer diameter table

small end OD (mm)	60	70	80	90	100	110	120	130	140	150	160	170	180	190	200	210
pole length (m)	Big end outer diameter table (mm)															
2	86	96	106	116	126	136	146	156	166	176	186	196	206	216	226	236
3	99	109	119	129	139	149	159	169	179	189	199	209	219	229	239	249
4	112	122	132	142	152	162	172	182	192	202	212	222	232	242	252	262
5	125	135	145	155	165	175	185	195	205	215	225	235	245	255	265	
6	138	148	158	168	178	188	198	208	218	228	238	248	258	268		
7	151	161	171	181	191	201	211	221	231	241	251	261				
8	164	174	184	194	204	214	224	234	244	254	264					
9	177	187	197	207	217	227	237	247	257	267						
10	190	200	210	220	230	240	250	260								
11	203	213	223	233	243	253	263									
12	216	226	236	246	256	266										

# ROUND CONICAL POLES

## ROUND CONICAL STREET LIGHTING POLES WITH LONG BRACKET

Arm Size (mm)			
"h1"	"L"	"R"	" $\phi D \times t$ "
1,000	1,000	700	60.3 x 2.90
1,000	1,500	700	60.3 x 2.90
1,000	1,500	700	60.3 x 2.90
2,000	2,000	1,000	60.3 x 3.65
2,000	2,500	1,500	60.3 x 3.65
2,000	2,500	1,500	60.3 x 3.65

Door Opening (mm)		
"A"	"B"	"C"
600	400	100
600	400	100
600	400	100
600	400	100
600	500	120
600	500	120

### Pole + Bracket Details

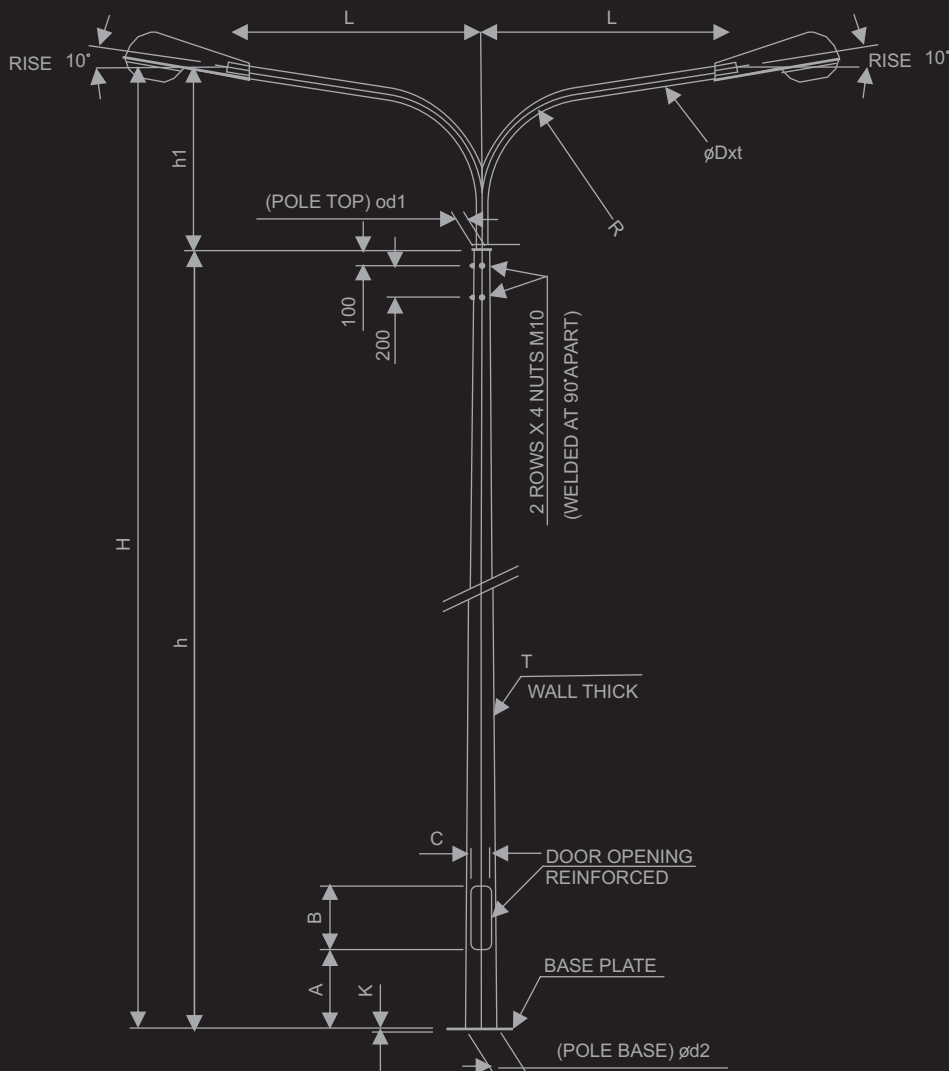

### Door Opening Details

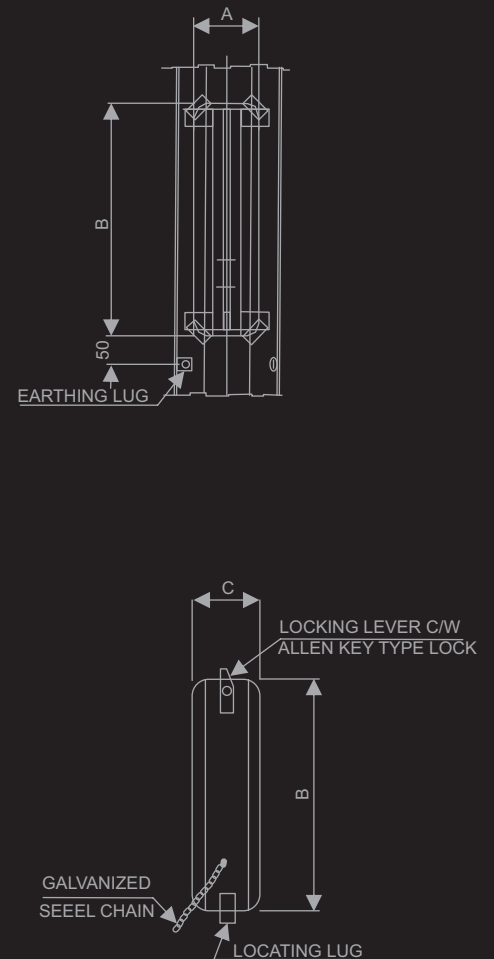

# ROUND CONICAL POLES

## ROUND CONICAL STREET LIGHTING POLES WITH LONG BRACKET

Flange/Base Plate Size (mm)				
"D"	"E"	"F"	"G"	"K"
400	300	22	35	10
400	300	28	45	15
400	300	28	45	15
400	300	28	45	15
400	300	32	50	20
400	350	32	50	20

Anchor Bolts Size (mm)			
"ØPxQ"	"R"	"M"	"Qty"
18x400	50	100	4 Nos
24x500	50	100	4 Nos
24x500	50	100	4 Nos
24x500	50	100	4 Nos
27x700	50	100	4 Nos
27x700	75	100	4 Nos

### Abbreviations/Notes

Abbreviations :

Arm Size:

h 1 = Bracket height,

L = Outreach

R = Radius

Dxt = Diameter x thickness.

Door Opening:

A= Door opening ht above ground

B = Door size

C = Door width.

Flange/Base Plate :

D = Dimension

E = Dist. between holes

F = Hole width

G = Hole length

K = Plate Thickness.

Anchor Bolts :

P = Bolt dia

Q = Bolt height

R = Radius

N = Bending height

Q = No. of bolts required/Pole.

Notes:

- All dimensions are in mm
- Design compliance with EN 40:2000 Loads BS CP3, Chapter 5, Part-2
- Maximum wind speed 160 Km/Hr.
- Finish: Hot dip galvanized to BS ISO1461 (or as specified).
- Accessories are made of Mild Steel Grade
- Shaft made of Steel Grade FE 510C (According to EN 10025).

### Flange Plate Details

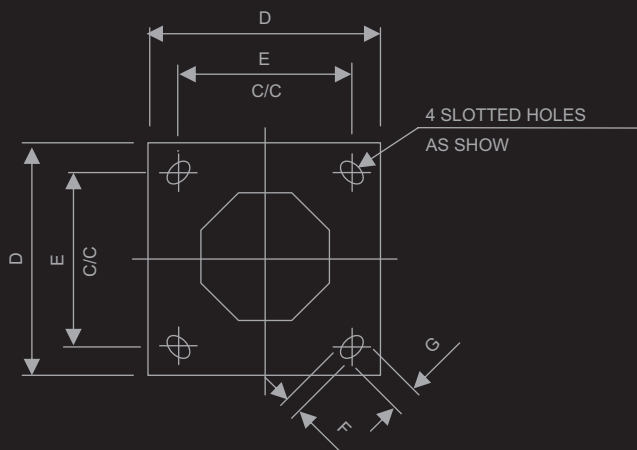

### Anchor Bolt Details

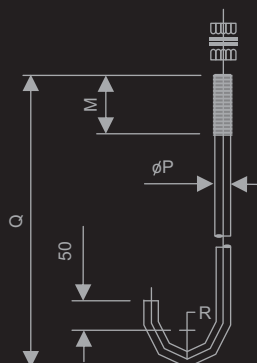

# ROUND CONICAL POLES

## ROUND CONICAL STREET LIGHTING POLES WITH LONG BRACKET

Arm Size (mm)		
"h1"	"L"	" $\varnothing D \times t$ "
190	500	60.3 x 2.90
225	700	60.3 x 2.90
275	1,000	60.3 x 2.90
375	1,500	60.3 x 3.65

Door Opening (mm)		
"A"	"B"	"C"
600	400	100
600	400	100
600	400	100
600	400	110

Pole + Bracket Details

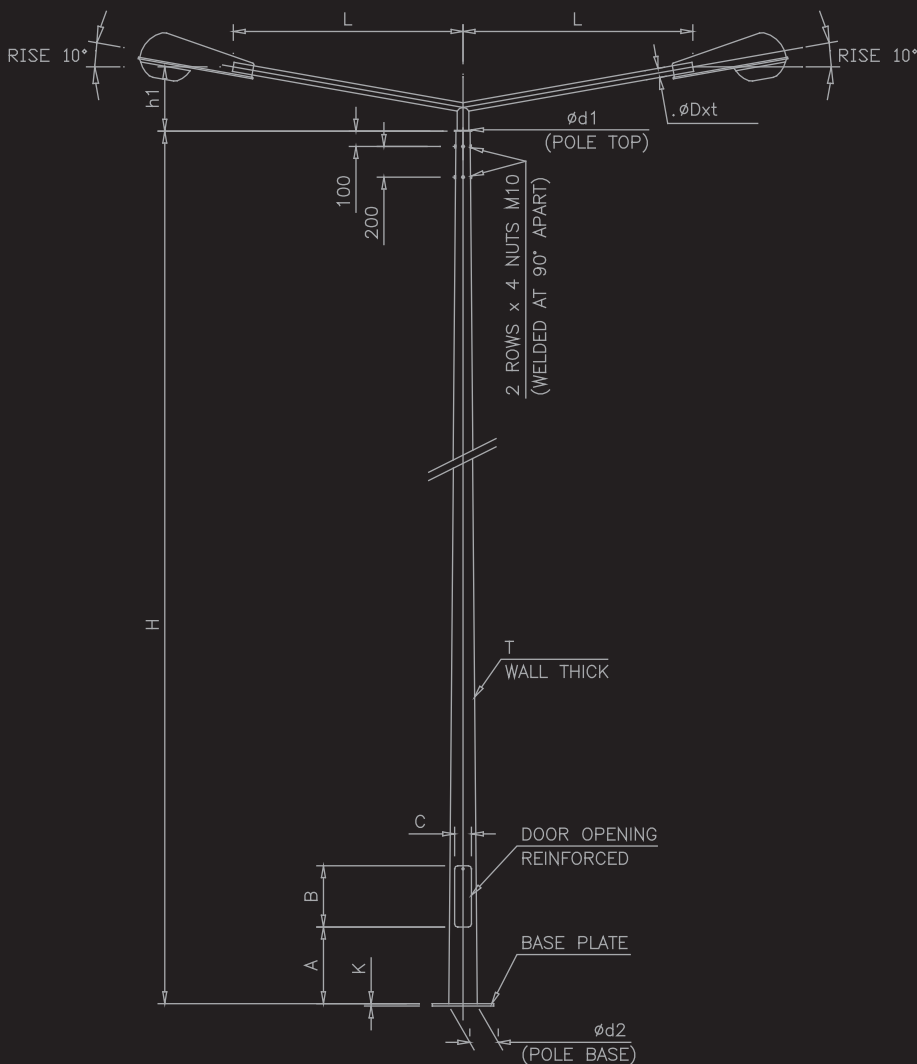

Door Opening Details

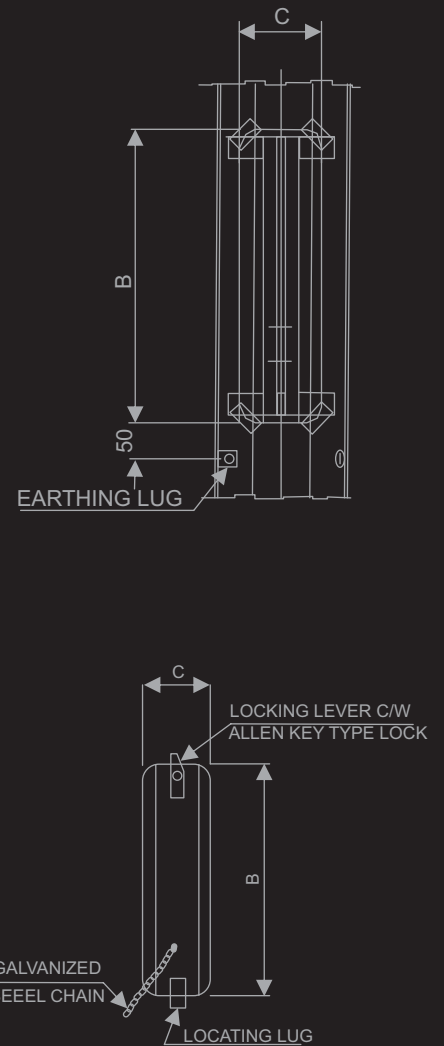

# ROUND CONICAL POLES

## ROUND CONICAL STREET LIGHTING POLES WITH LONG BRACKET

Flange/Base Plate Size (mm)

"D"	"E"	"F"	"G"	"K"
400	300	22	35	10
400	300	28	45	15
400	300	28	45	15
400	300	28	45	15

Anchor Bolts Size (mm)

"ØPxQ"	"R"	"M"	"Qty"
18x400	50	100	4 Nos
24x500	50	100	4 Nos
24x500	50	100	4 Nos
24x500	50	100	4 Nos

Abbreviations/Notes

Abbreviations :

Arm Size:  
h 1 = Bracket height,  
L = Outreach  
Dxt = Diameter x thickness.

Door Opening:  
A= Door opening ht above ground  
B = Door size  
C = Door width.

Flange/Base Plate :  
D = Dimension  
E = Dist. between holes  
F = Hole width  
G = Hole length  
K = Plate Thickness.

Anchor Bolts :  
P = Bolt dia  
Q = Bolt height  
R = Radius  
N = Bending height  
Q = No. of bolts required/Pole.

Notes:

1. All dimensions are in mm
2. Design compliance with EN 40:2000 Loads BS CP3, Chapter 5, Part-2
3. Maximum wind speed 160 Km/Hr.
4. Finish: Hot dip galvanized to BS ISO1461 (or as specified).
5. Accessories are made of Mild Steel Grade
6. Shaft made of Steel Grade FE 510C (According to EN 10025).

Flange Plate Details

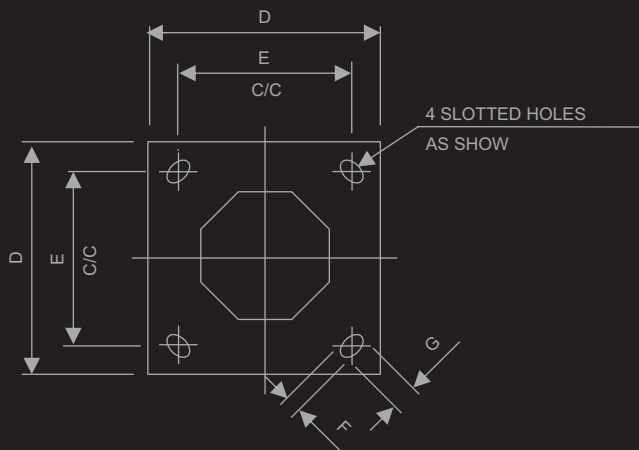

Anchor Bolt Details

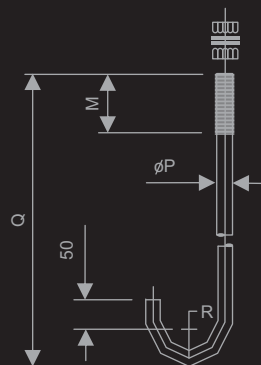

# ROUND CONICAL POLES

## ROUND CONICAL STREET LIGHTING POLES WITH SHORT BRACKET

Arm Size (mm)

"h1"	"L"	"OD xt"
200	500	60.3 x 3.00
200	500	60.3 x 3.00
200	500	60.3 x 3.00
200	500	60.3 x 3.00
200	500	60.3 x 3.00

Dor Opening (mm)

"A"	"B"	"C"
600	500	120
600	500	120
600	500	140
600	500	140
600	500	140

Pole + Bracket Details

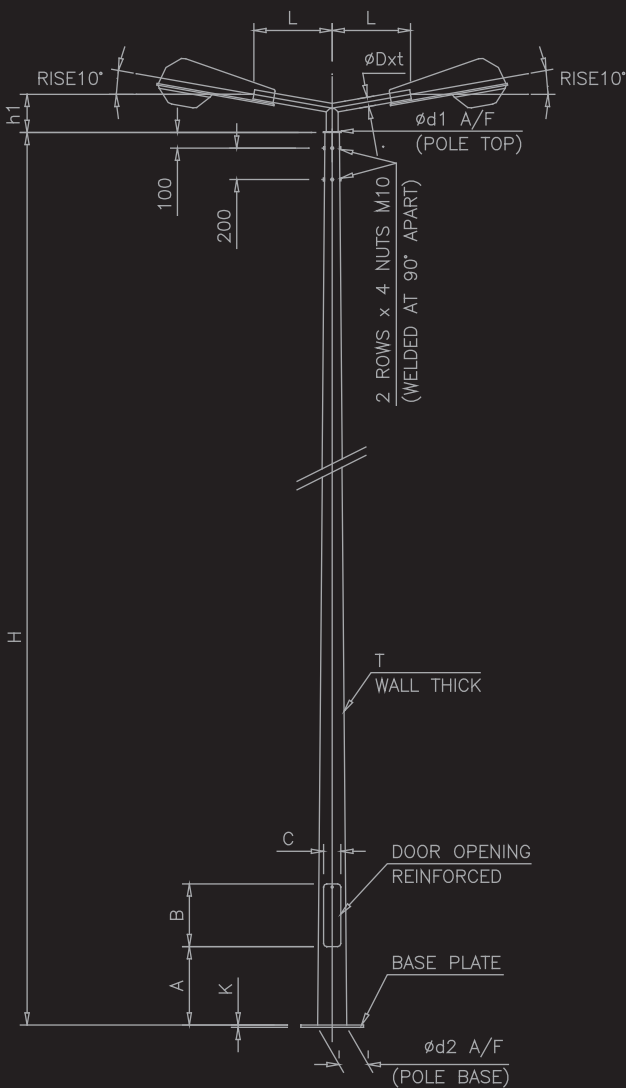

Door Opening Details

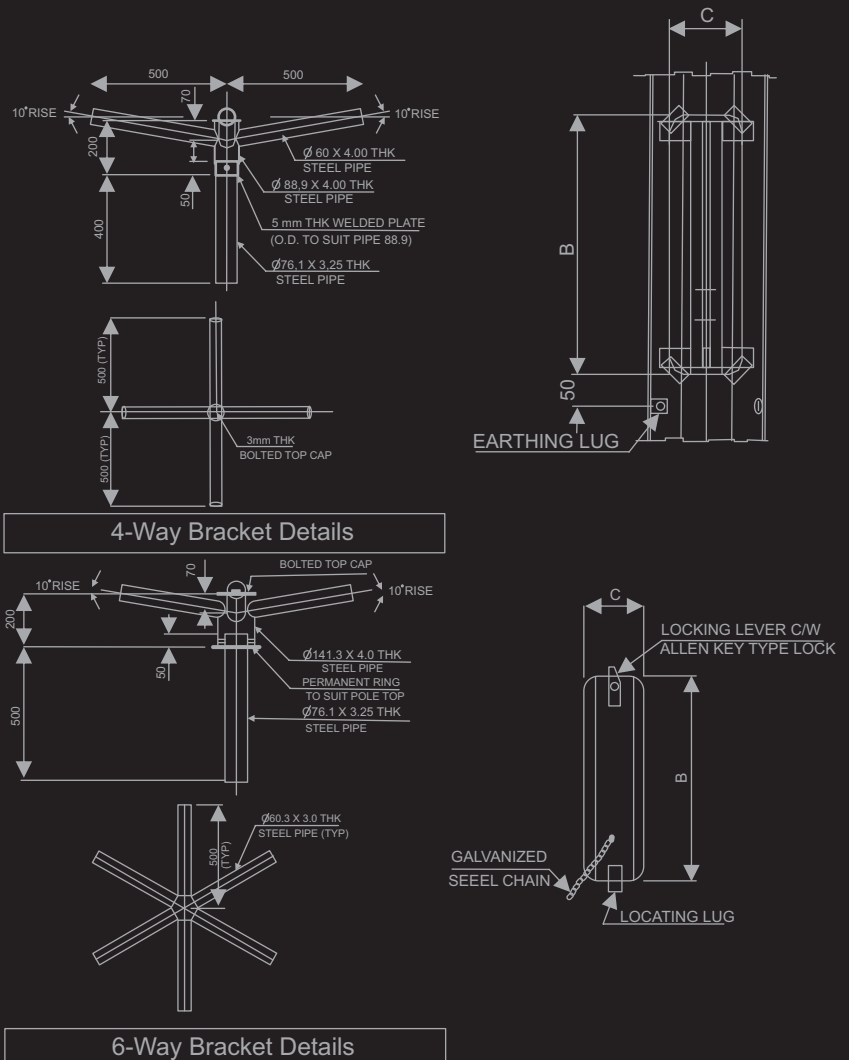

# ROUND CONICAL POLES

## ROUND CONICAL STREET LIGHTING POLES WITH SHORT BRACKET

Flange/Base Plate Size (mm)				
"D"	"E"	"F"	"G"	"K"
400	300	32	45	20
400	300	32	50	25
450	350	35	50	25
450	350	35	50	30
500	400	38	50	35

Anchor Bolts Size (mm)			
"OPxQ"	"R"	"R"	"Qty"
27x700	75	120	4 Nos
27x900	75	150	4 Nos
30x1000	75	150	4 Nos
30x1000	75	150	4 Nos
32x1000	75	150	4 Nos

### Abbreviations/Notes

Abbreviations :

Arm Size:

h 1 = Bracket height,

L = Outreach

Dxt = Diameter x thickness.

Door Opening:

A= Door opening ht above ground

B = Door size

C = Door width.

Flange/Base Plate :

D = Dimension

E = Dist. between holes

F = Hole width

G = Hole length

K = Plate Thickness.

Anchor Bolts :

P = Bolt dia

Q = Bolt height

R = Radius

N = Bending height

Q = No. of bolts required/Pole.

Notes:

- All dimensions are in mm
- Design compliance with EN 40:2000 Loads BS CP3, Chapter 5, Part-2
- Maximum wind speed 160 Km/Hr.
- Finish: Hot dip galvanized to BS ISO1461 (or as specified).
- Accessories are made of Mild Steel Grade
- Shaft made of Steel Grade FE 510C (According to EN 10025).

### Flange Plate Details

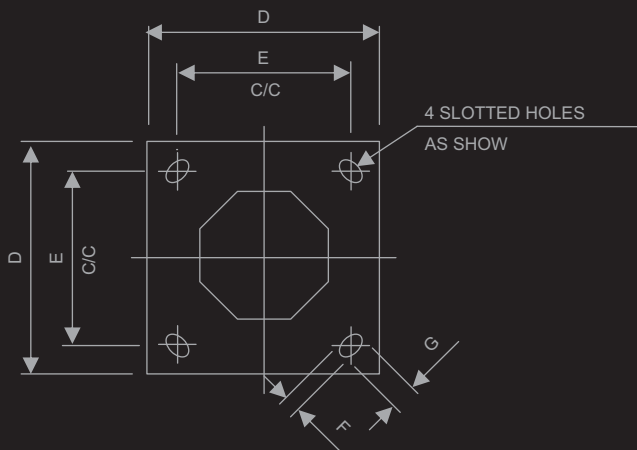

### Anchor Bolt Details

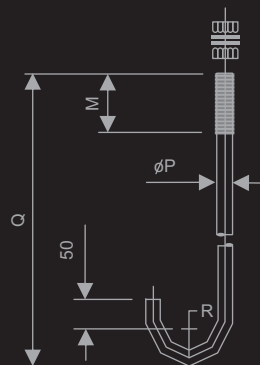



# HIGH MAST POLES



# HIGH MASTS POLES

High Masts Poles, engineered for optimal illumination over expansive areas, stand as the ideal solution for lighting applications such as sports grounds, stadia, highways, highway interchanges, airports, harbors, and open parking lots. At Atom Poles, our High Masts Poles are meticulously manufactured, ranging in height from 18 to 30 meters or even exceeding these dimensions. They feature a distinctive polygonal shape crafted from continuous tapered steel and are seamlessly electrically welded for unparalleled structural integrity.

The mast itself is an assembly of 2 to 4 shafts, precision-joined through a method of pressure over-lapping. This sectional construction not only ensures a robust grip but also allows for seamless integration, creating a cohesive and durable structure. The shafts are connected by telescopic slings, further enhancing stability and contributing to the overall strength of the High Masts Poles.

One notable feature of our High Masts Poles is their versatility in design. They can be equipped with raising and lowering devices, offering convenient adjustability for varying lighting requirements. Alternatively, they are available with a fixed rectangular and tilted headframe, providing a customized solution to meet specific project needs.

Beyond their functional excellence, Atom Poles takes pride in the aesthetic appeal of our High Masts Poles. The polygonal shape and streamlined design not only serve a practical purpose but also contribute to the visual enhancement of the surrounding environment. These High Masts Poles exemplify our commitment to delivering cutting-edge solutions that seamlessly blend form and function, meeting the diverse needs of modern infrastructure projects.

## POLYGONAL HIGHMAST

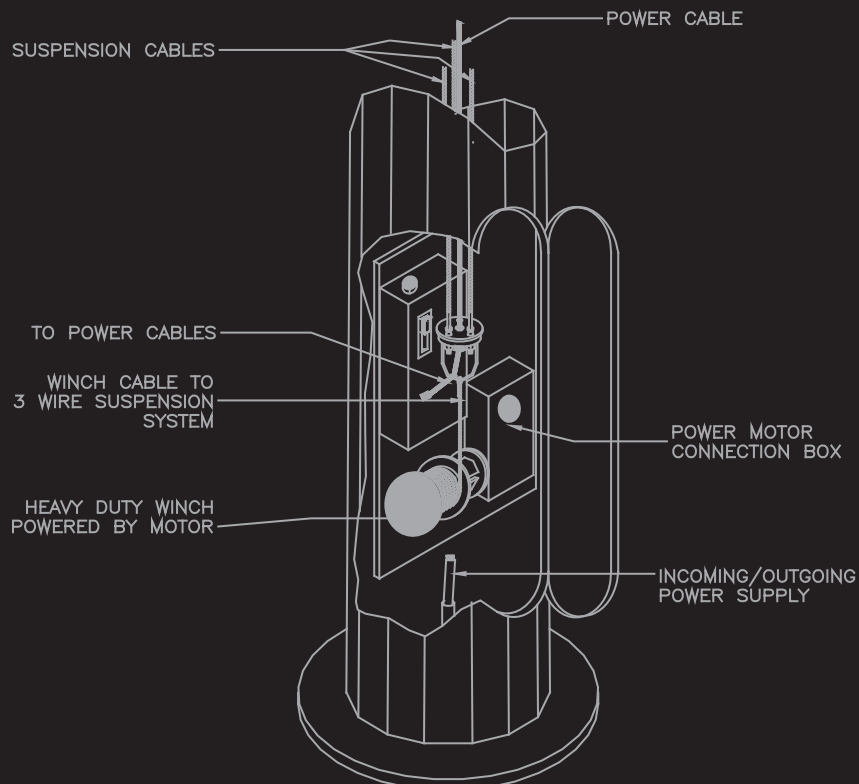
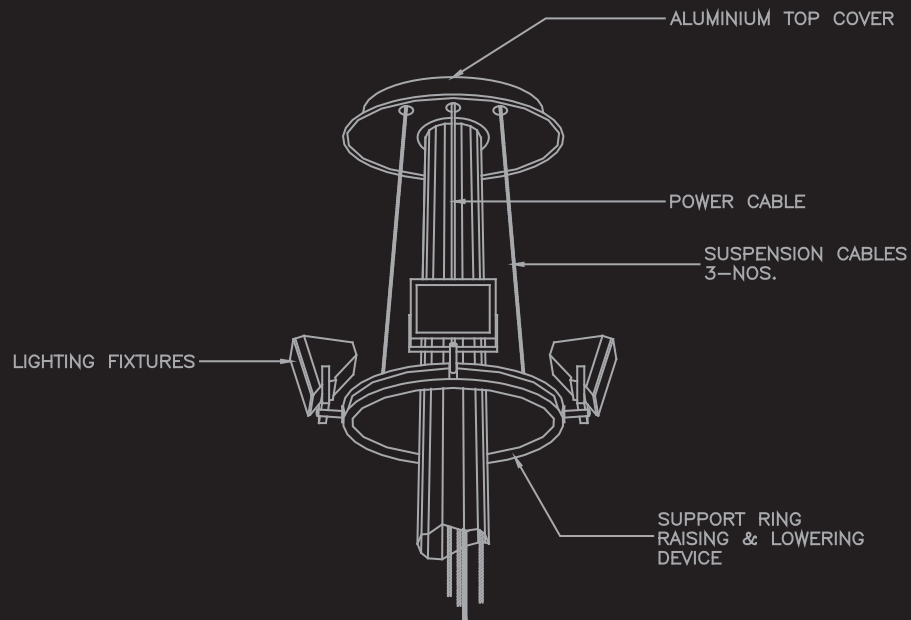

# HIGH MASTS POLES

## POLYGONAL HIGHMAST

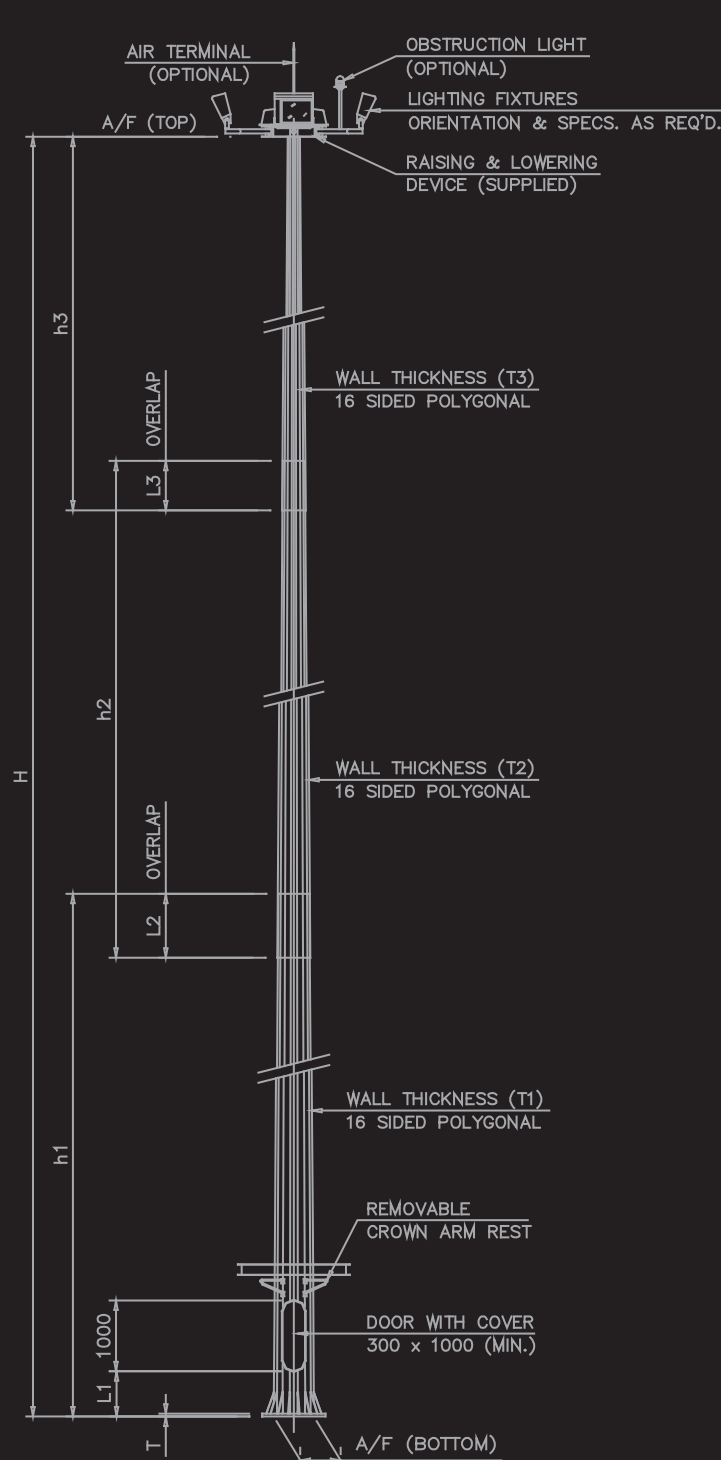

Typical Polygonal Highmast

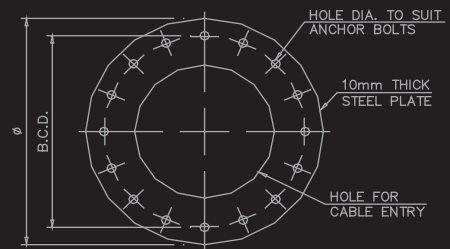

Foundation Template

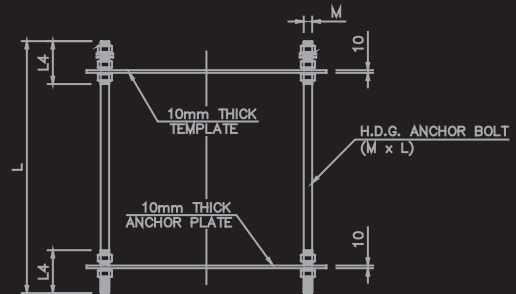

Foundation Bolt Frame

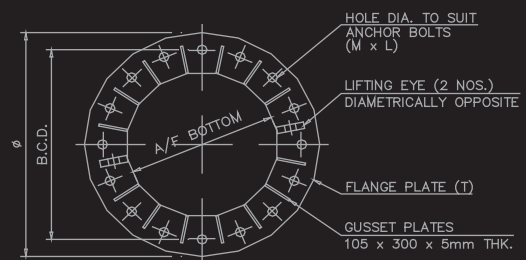

Base Plate Detail

Abbreviations :

- 1) Highmast :  
 H = Overall height  
 h1 = Size of bottom shaft  
 h2 = Size of middle shaft  
 h3 = Size of top shaft  
 T = Base Plate Thickness

Notes :

- All dimensions are in mm
- Finish : Hot dip galvanized to BS ISO 1461 (or as specified).
- Accessories are made of Mild Steel Grade. Shaft made of Steel Grade FE 510C (According to EN 10025).

# HIGH MASTS POLES

Highmasts are ideally suitable for the lighting of wide areas like sportground, stadia, highways, highway interchanges, Airports, Harbours, open parking lots etc. Highmasts are manufactured from 8 to 50 Metre or above and are polygonal in shape with continuous tapered steel electrically welded. The mast is an assembly of 2-4 shafts joined together by means of pressure over-lapping, section per section, rendering firm grip and are joined by telescopic slings. Masts are designed according to the technical report No. 7 of the Association of Public Lighting Engineers, London. They are designed to withstand PRs Seika hc teisa each materiel kelicatteyat a height of 10 Metre above ground level and it is ensured that oscillations are damped to a minimum to avoid its failure due to fatigue. Rectangular and tilted headframes are normally used for the highmasts which are accessed to the top by means of removable steps or caged ladder. Mobile circular type of headframes are used for highmasts with raising and lowering devices. In this case a hoisting unit is used to raise and lower the circular headframes. The raising and lowering device for circular head frame carrying lighting fixtures consists of :

- Winch with handle
- Winch cable to 3-wire suspension system
- Power cable
- Top crown
- Lighting fixtures support ring
- Junction box
- Power cable sheave
- Power tool

Polygonal Highmasts from 8 Metre height and over, optionally available with raising and lowering devices are normally used for lighting Expressways, Stadia, Harbours, big open parking lots etc. The Highmast is an assembly of 2-4 shafts joined together by means of pressure over-lapping, section per section, rendering firm grip and are joined by telescopic slings.

# HIGH MASTS POLES

Following are some standard sized highmasts :

Highmast Size (mm)						
"H"	"d1" (a/f)	"d2" (a/f)	"h1 x T1"	"h2 x T2"	"h3 x T3"	"h4 x T4"
8,000	150	430	8000 x 4	--	--	--
12,000	161	440	12000 x 4	--	--	--
15,000	161	440	10000 x 4	5600 x 4	--	--
16,000	161	440	10000 x 4	6600 x 4	--	--
18,000	161	440	10000 x 4	8700 x 4	--	--
20,000	161	440	10000 x 4	10800 x 4	--	--
25,000	161	475	10800 x 4	10000 x 4	5600 x 4	--
30,000	161	500	9600 x 5	11000 x 4	11000 x 4	--
35,000	161	610	9600 x 6	11000 x 5	11000 x 4	5600 x 4
38,000	200	650	11000 x 6	11000 x 5	11000 x 4	7500 x 4
40,000	200	650	11000 x 6	11000 x 5	11000 x 4	9500 x 4

Mast	Door Opening			Flange/Base Plate Size (mm)						Anchor Bolts (mm)		
	"A"	"B"	"C"	"D"	"E"	"F"	"K"	"G"	"M"	"P x Q"	"N"	"Qty"
8,000	600	1000	300	700	580	35	30	32	10	30 x 940	160	6
12,000	600	1000	300	750	620	35	30	32	10	30 x 940	160	8
15,000	600	1000	300	750	620	35	30	32	10	30 x 940	160	8
16,000	600	1000	300	750	620	35	35	32	10	30 x 940	160	8
18,000	600	1000	300	750	620	35	35	32	10	30 x 940	160	8
20,000	600	1000	300	750	620	35	35	32	10	30 x 940	160	10
25,000	600	1000	300	750	620	35	35	32	10	30 x 940	160	12
30,000	600	1000	300	800	680	35	40	32	14	30 x 940	160	16
35,000	600	1000	300	1000	850	35	50	32	15	30 x 940	160	18
38,000	600	1000	300	1050	900	35	50	32	15	30 x 940	160	20
40,000	600	1000	300	1050	900	35	50	32	15	30 x 940	160	20

# OCTAGONAL POLES



# OCTAGONAL POLES

Octagonal Poles, a hallmark of structural excellence, are meticulously crafted through a sophisticated manufacturing process at Atom Poles. Our commitment to quality begins with the careful selection of high-grade hot-rolled steel coils, ensuring the foundation of durability and strength for each pole.

The production journey unfolds with an automated procedure that intricately cuts and folds or presses the trapezoidal sheet into the iconic octagonal shape. This precision is not only a testament to our dedication to detail but also a guarantee of uniformity and structural integrity. The octagonal configuration is achieved with a keen focus on maintaining dimensional accuracy, allowing these poles to seamlessly integrate into diverse infrastructure applications.

What sets our Octagonal Poles apart is the longitudinal welding technique employed during production. Through submerged arc welding, the sides are seamlessly bonded, further enhancing the structural stability and longevity of the poles. This welding method ensures a robust connection that withstands environmental stresses and contributes to the overall reliability of the infrastructure.

As a result, Atom Poles proudly delivers Octagonal Poles that not only meet but exceed industry standards. From highway and street lighting to traffic signage, electrical distribution, and transmission towers, our octagonal poles stand as a symbol of innovation and excellence in the realm of infrastructure products. Additionally, their adaptability extends to applications such as wireless communication towers, high mast and sport lighting poles, transit poles and wind tower poles.

In our pursuit of excellence, we go beyond functionality. Atom Poles offers a diverse range of Octagonal Poles that not only serve practical purposes but also contribute to the visual aesthetics of urban landscapes. Whether it's the precision in design or the robustness in construction, our Octagonal Poles exemplify the intersection of engineering prowess and a commitment to quality that defines Atom Poles in the realm of infrastructure solutions.



# OCTAGONAL POLES

## OCTAGONON STREET LIGHTING POLES WITH LONG BRACKET

Pole Size (mm)				
"H"	"h"	"d1"	"d2"	"Thk"
6,000	5,000	75	130	4
8,000	7,000	75	156	4
9,000	8,000	75	156	4
10,000	8,000	75	180	4
12,000	10,000	90	250	4
14,000	12,000	90	285	4

Arm Size (mm)			
"h1"	"L"	"R"	"ØD x t"
1,000	1,000	700	60.3 x 2.90
1,000	1,500	700	60.3 x 2.90
1,000	1,500	700	60.3 x 2.90
2,000	2,000	1,000	60.3 x 3.65
2,000	2,500	1,500	60.3 x 3.65
2,000	2,500	1,500	60.3 x 3.65

Door Opening (mm)		
"A"	"B"	"C"
600	400	100
600	400	100
600	400	100
600	400	100
600	500	120
600	500	120

### Pole + Bracket Details

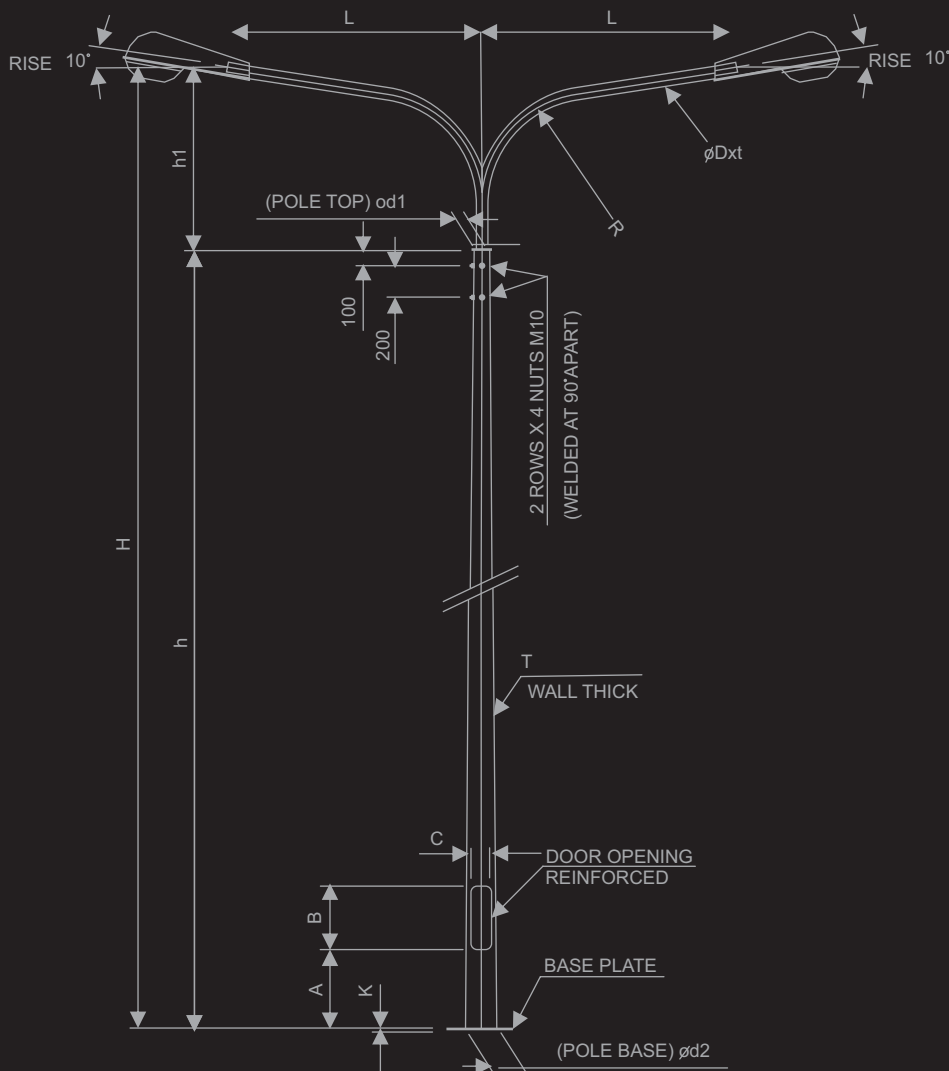

### Door Opening Details

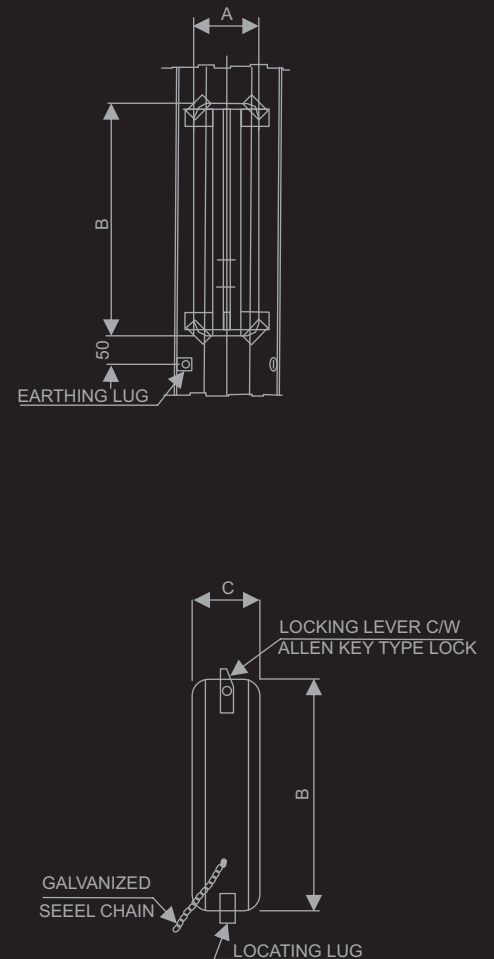

# OCTAGONAL POLES

## OCTAGON STREET LIGHTING POLES WITH LONG BRACKET

Flange/Base Plate Size (mm)				
"D"	"E"	"F"	"G"	"K"
400	300	22	35	10
400	300	28	45	15
400	300	28	45	15
400	300	28	45	15
400	300	32	50	20
400	350	32	50	20

Anchor Bolts Size (mm)			
"ØPxQ"	"R"	"M"	"Qty"
18x400	50	100	4 Nos
24x500	50	100	4 Nos
24x500	50	100	4 Nos
24x500	50	100	4 Nos
27x700	50	100	4 Nos
27x700	75	100	4 Nos

### Abbreviations/Notes

Abbreviations :

- I) Pole Size :  
H = Overall height  
h = Shaft height  
d1 = Top dia.  
d2 = Bottom dia.  
Thk = ShaftWallThickness
- (II) Arm Size:  
h 1 = Bracket height,  
L = Outreach  
R = Radius  
Dxt = Diameter x thickness.
- (III) Door Opening:  
A= Door opening ht above ground  
B = Door size  
C = Door width.
- (IV) Flange/Base Plate :  
D = Dimension  
E = Dist. between holes  
F = Hole width  
G = Hole length  
K = Plate Thickness.
- (V) Anchor Bolts :  
P = Bolt dia  
Q = Bolt height  
R = Radius  
N = Bending height  
Q = No. of bolts required/Pole.

### Flange Plate Details

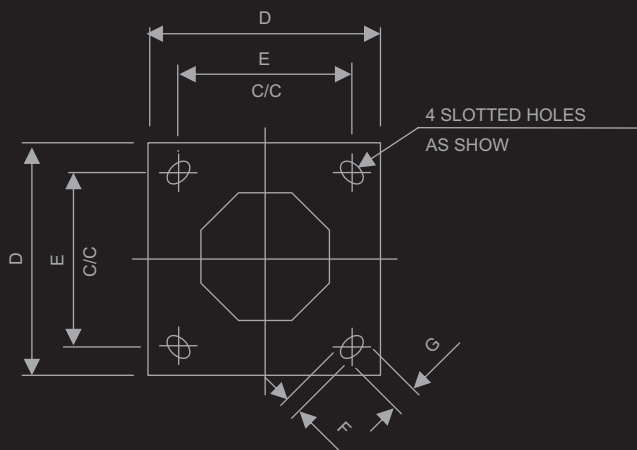

### Anchor Bolt Details

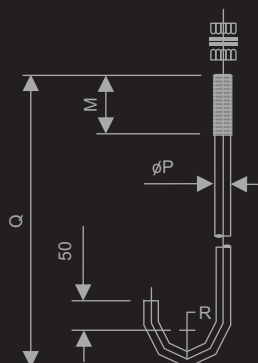

Notes:

1. All dimensions are in mm
2. Design compliance with EN 40:2000 Loads BS CP3, Chapter 5, Part-2
3. Maximum wind speed 160 Km/Hr.
4. Finish: Hot dip galvanized to BS ISO1461 (or as specified).
5. Accessories are made of Mild Steel Grade
6. Shaft made of Steel Grade FE 510C (According to EN 10025).



# OCTAGONAL POLES

## OCTAGON STREET LIGHTING POLES WITH LONG BRACKET

Flange/Base Plate Size (mm)

"D"	"E"	"F"	"G"	"K"
400	300	22	35	10
400	300	28	45	15
400	300	28	45	15
400	300	28	45	15

Anchor Bolts Size (mm)

"ØPxQ"	"R"	"M"	"Qty"
18x400	50	100	4 Nos
24x500	50	100	4 Nos
24x500	50	100	4 Nos
24x500	50	100	4 Nos

Abbreviations/Notes

Abbreviations :

- I) Pole Size :  
H = Shaft height  
d1 = Top dia.  
d2 = Bottom dia.  
Thk = ShaftWallThickness
- (II) Arm Size:  
h 1 = Bracket height,  
L = Outreach  
Dxt = Diameter x thickness.
- (III) Door Opening:  
A= Door opening ht above ground  
B = Door size  
C = Door width.
- (IV) Flange/Base Plate :  
D = Dimension  
E = Dist. between holes  
F = Hole width  
G = Hole length  
K = Plate Thickness.
- (V) Anchor Bolts :  
P = Bolt dia  
Q = Bolt height  
R = Radius  
N = Bending height  
Q = No. of bolts required/Pole.

Flange Plate Details

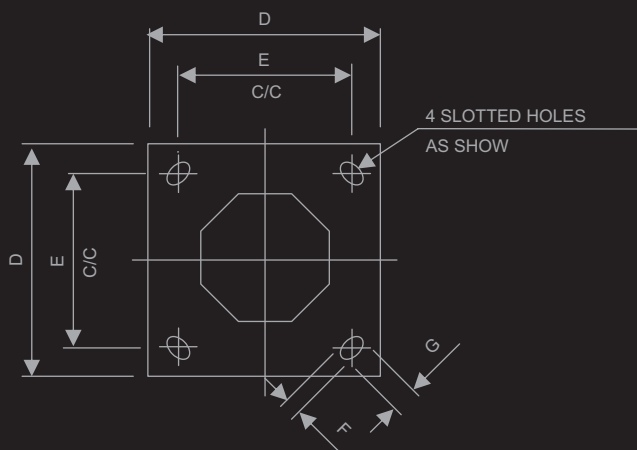

Anchor Bolt Details

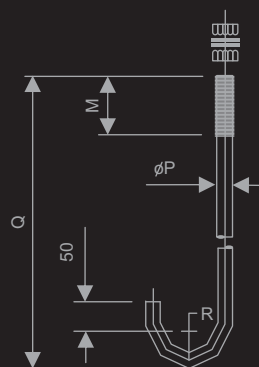

Notes:

1. All dimensions are in mm
2. Design compliance with EN 40:2000 Loads BS CP3, Chapter 5, Part-2
3. Maximum wind speed 160 Km/Hr.
4. Finish: Hot dip galvanized to BS ISO1461 (or as specified).
5. Accessories are made of Mild Steel Grade
6. Shaft made of Steel Grade FE 510C (According to EN 10025).

# OCTAGONAL POLES

## OCTAGON STREET LIGHTING POLES WITH SHORT BRACKET

Pole Size (mm)

"H"	"d1"	"d2"	"T"	
12.000	90	250	4	—
14.000	90	285	4	—
15.000	105	300	5	4
16.000	105	320	5	4
18.000	105	375	5	4

Arm Size (mm)

"h1"	"L"	"OD xt"
200	500	60.3 x 3.00
200	500	60.3 x 3.00
200	500	60.3 x 3.00
200	500	60.3 x 3.00
200	500	60.3 x 3.00

Door Opening (mm)

"A"	"B"	"C"
600	500	120
600	500	120
600	500	140
600	500	140
600	500	140

Pole + Bracket Details

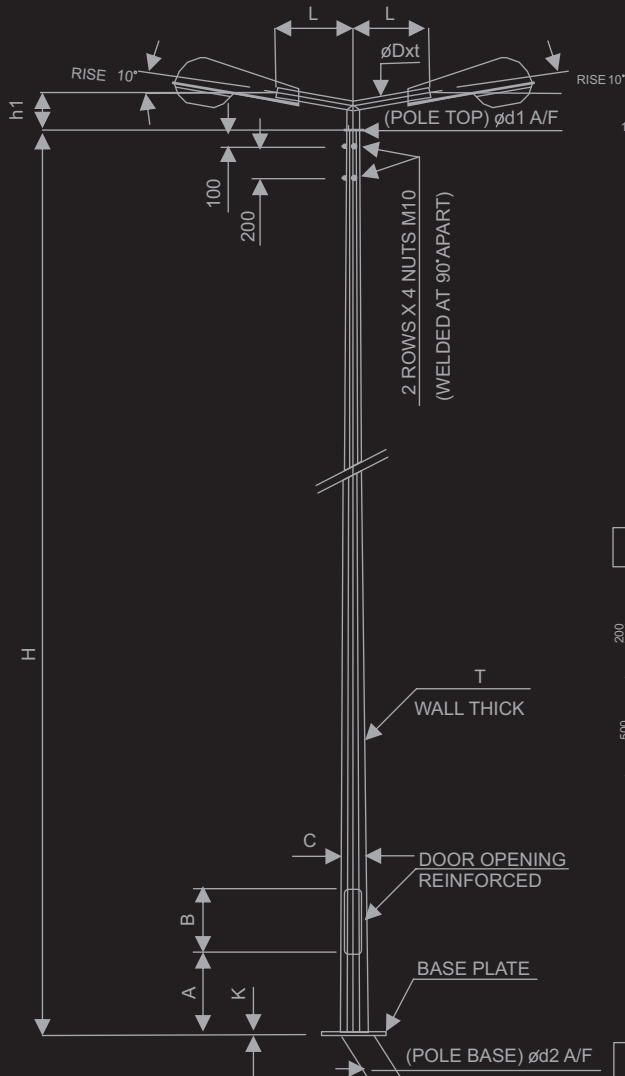

Door Opening Details

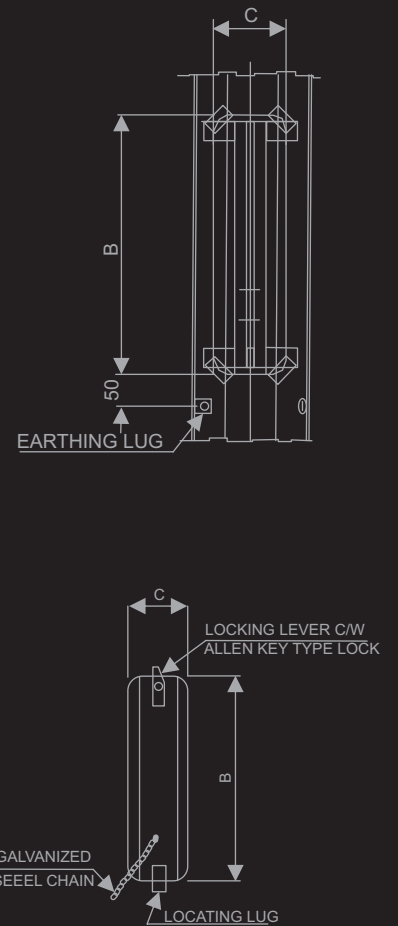

4-Way Bracket Details

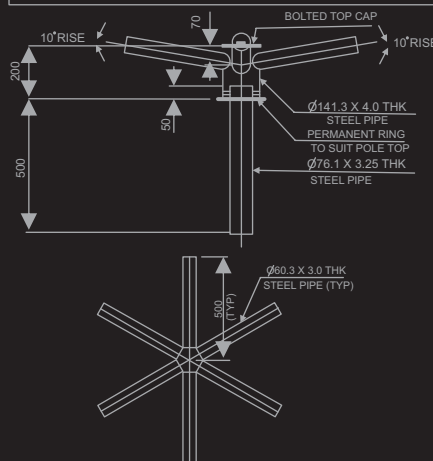

6-Way Bracket Details

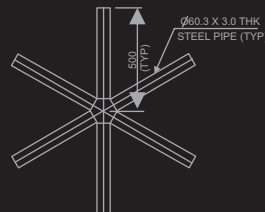

# OCTAGONAL POLES

## OCTAGON STREET LIGHTING POLES WITH SHORT BRACKET

Flange/Base Plate Size (mm)				
"D"	"E"	"F"	"G"	"K"
400	300	32	45	20
400	300	32	50	25
450	350	35	50	25
450	350	35	50	30
500	400	38	50	35

Anchor Bolts Size (mm)			
"OPxQ"	"R"	"R"	"Qty"
27x700	75	120	4 Nos
27x900	75	150	4 Nos
30x1000	75	150	4 Nos
30x1000	75	150	4 Nos
32x1000	75	150	4 Nos

### Abbreviations/Notes

#### Abbreviations :

#### Pole Size :

H = Shaft height

d1 = Top dia.

d2 = Bottom dia.

Thk = ShaftWallThickness

#### Arm Size:

h 1 = Bracket height,

L = Outreach

Dxt = Diameter x thickness.

#### Door Opening:

A= Door opening ht above ground

B = Door size

C = Door width.

#### Flange/Base Plate :

D = Dimension

E = Dist. between holes

F = Hole width

G = Hole length

K = Plate Thickness.

#### Anchor Bolts :

P = Bolt dia

Q = Bolt height

R = Radius

N = Bending height

Q = No. of bolts required/Pole.

#### Notes:

- All dimensions are in mm
- Design compliance with EN 40:2000 Loads BS CP3, Chapter 5, Part-2
- Maximum wind speed 160 Km/Hr.
- Finish: Hot dip galvanized to BS ISO1461 (or as specified).
- Accessories are made of Mild Steel Grade
- Shaft made of Steel Grade FE 510C (According to EN 10025).

### Flange Plate Details

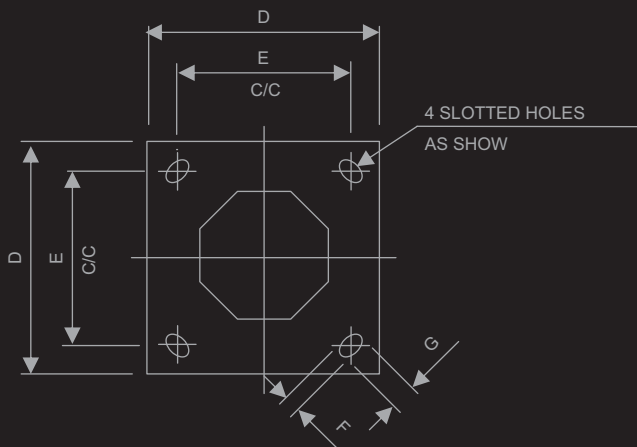

### Anchor Bolt Details

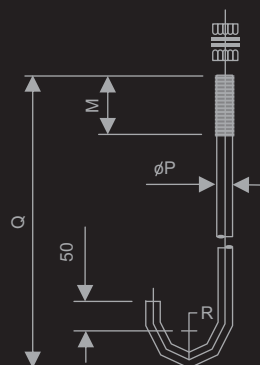

# STEPPED POLES



# STEPPED POLES

Stepped Poles, a hallmark of innovative engineering, undergo a distinctive manufacturing process at Atom Poles, utilizing a unique hot-swaged joint method that sets them apart in terms of strength and durability. This method involves the application of heat to seamlessly fix a larger diameter pipe into a smaller diameter pipe, resulting in fused pipe joints of remarkable strength.

The key advantage of this hot-swaged joint method lies in its ability to create watertight joints, ensuring the overall pole maintains its strength consistently across its entire length. Unlike traditional methods that involve welding, the absence of welding in the production of Stepped Poles is a significant benefit. This absence means that joints do not experience weakening over their lifetime, contributing to the long-term structural integrity and reliability of the poles.

At Atom Poles, our commitment to quality shines through in the meticulous craftsmanship of Stepped Poles. The innovative hot-swaged joint method not only enhances strength but also eliminates potential vulnerabilities associated with welded joints. This makes Stepped Poles an ideal choice for various applications, offering robust solutions for highway and street lighting, traffic signage, electrical distribution, and transmission towers.

In addition to their functional excellence, Stepped Poles cater to a range of aesthetic needs, contributing to the visual appeal of urban landscapes. Atom Poles proudly stands behind the Stepped Poles, exemplifying our dedication to cutting-edge engineering practices that redefine industry standards and elevate the performance of infrastructure solutions.



# STEPPED POLES

## STEPPED STREET LIGHTING POLES WITH LONG BRACKET

Pole Size (mm)									Arm Size (mm)			
"H"	"h1"	"ØD1xt"	"h2"	"ØD2xt"	"h3"	ØD3xt	"h4"	ØD4xt	"h"	"L"	"R"	"ØD x t"
6,000	3,000	141.3x4.0	1800	88.9x3.25	--	--	--	--	1,200	1,000	700	60.3 x 2.90
7,000	3,000	141.3x4.0	1,800	114.3x4.0	1,000	76.1x3.25	--	--	1,200	1,000	700	60.3 x 2.90
8,000	3,000	168.3x4.0	1,800	114.3x4.00	2,000	76.1x3.25	--	--	1,200	1,500	700	60.3 x 2.90
9,000	3,000	168.3x4.0	2,800	114.3x4.0	2,000	76.1x3.25	--	--	1,200	1,500	700	60.3 x 2.90
10,000	4,000	168.3x4.0	2,800	114.3x4.0	2,000	76.1x3.25	--	--	1,200	1,500	700	60.3 x 2.90
12,000	4,000	193.7x4.0	3,800	114.3x4.0	2,200	76.1x3.25	--	--	2,000	2,000	1,000	60.3 x 3.65
14,000	4,000	219.1x5.6	3,750	141.3x4.0	2,800	114.3x4.00	1,450	88.9x3.6	2,000	2,500	1,500	60.3 x 3.65
15,000	4,000	219.1x5.6	3,750	193.7x4.0	3,800	168.3x4.00	1,450	114.3x4.0	2,000	2,500	1,500	60.3 x 3.65

Pole + Bracket Details

Door Opening Details

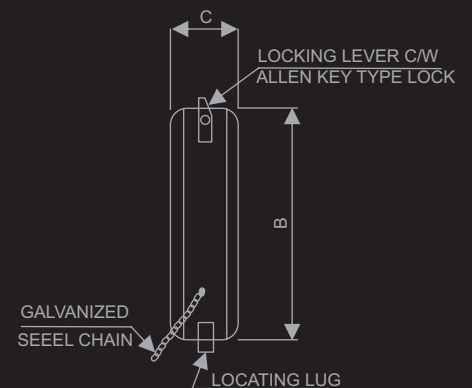
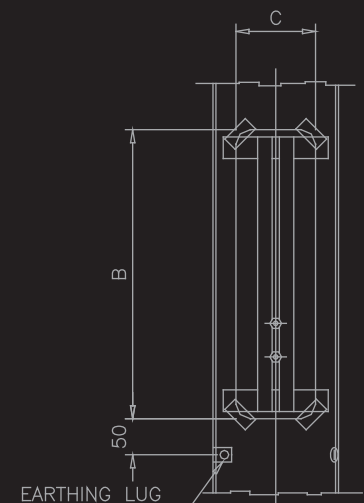
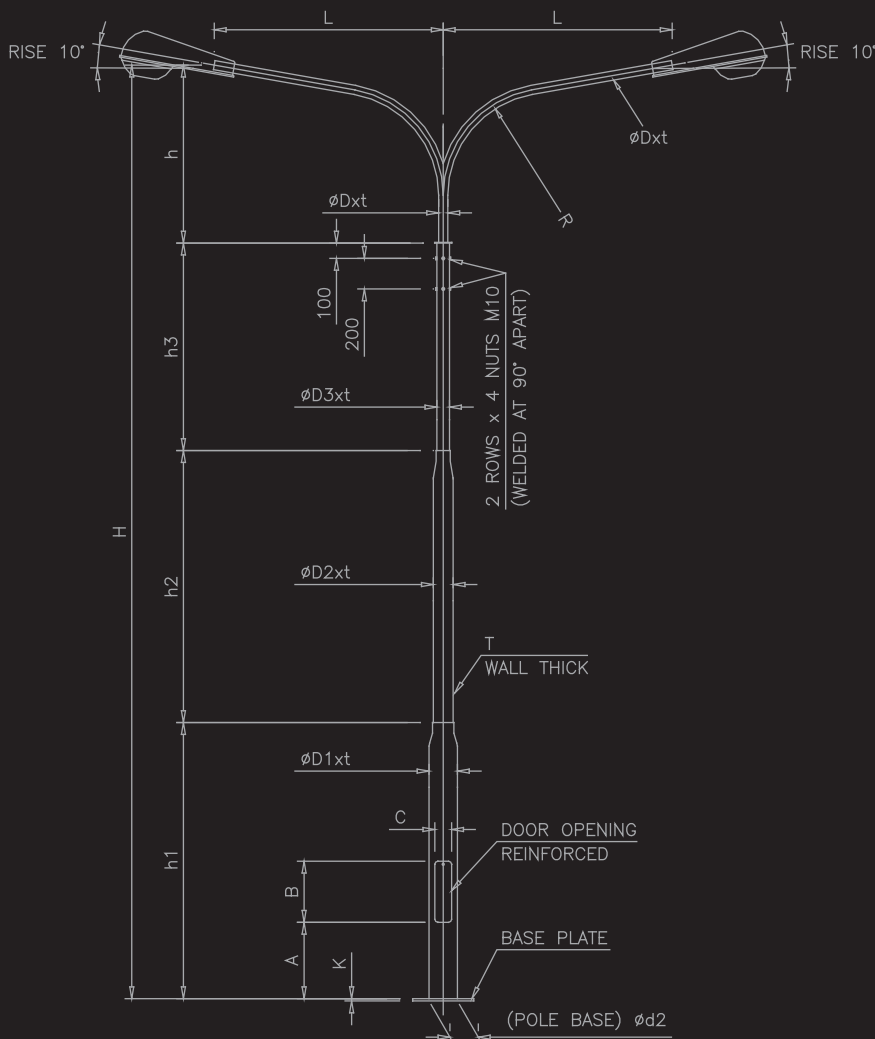

# STEPPED POLES

## STEPPED STREET LIGHTING POLES WITH LONG BRACKET

Door Opening			Flange Plate Size					Anchor Bolts Size				Abbreviations/Notes
"A"	"B"	"C"	"D"	"E"	"F"	"G"	"K"	"ØPxQ"	"R"	"M"	"Qty"	
600	300	70	300	200	22	35	10	18x400	50	100	4 Nos	Abbreviations :  <b>Pole Size :</b> H = Overall height h1 = Height of bottom shaft h2 = Height of middle shaft h3 = Height of top shaft t = Shaft Wall Thickness  <b>Arm Size :</b> h = Bracket height, L = Outreach R = Radius Dxt = Diameter x thickness.  <b>Door Opening :</b> A = Door opening ht above ground B = Door size C = Door width.  <b>Flange/Base Plate :</b> D = Dimension E = Dist. between holes F = Hole width G = Hole length K = Plate Thickness.  <b>Anchor Bolts :</b> P = Bolt dia Q = Bolt height R = Radius N = Bending height Q = No. of bolts required/Pole.
600	400	90	400	300	28	45	10	24x500	50	100	4 Nos	
600	400	90	400	300	28	45	10	24x500	50	100	4 Nos	
600	400	110	400	300	28	45	15	24x500	50	100	4 Nos	
600	400	110	400	300	28	50	15	27x500	50	100	4 Nos	
600	400	110	400	350	32	50	20	27x700	75	120	4 Nos	
600	500	120	400	300	32	45	25	27x700	75	120	4 Nos	
800	600	130	450	350	35	50	25	30x1000	75	150	4 Nos	

### Flange Plate Details

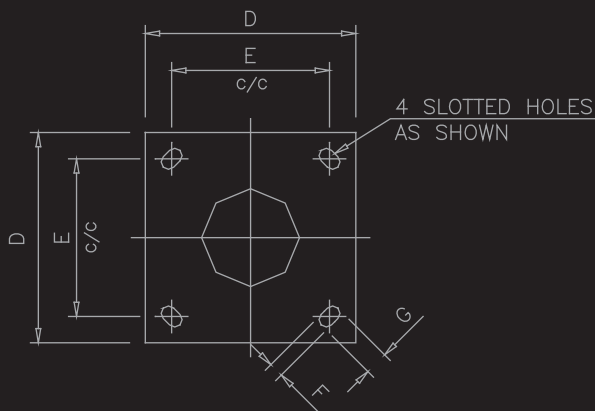

### Anchor Bolt Details

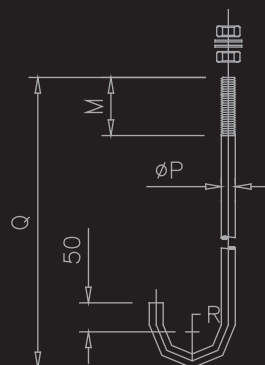

### Notes :

1. All dimensions are in mm
2. Design compliance with BS EN 40:2000 Loads BS CP3, Chapter 5, Part-2
3. Maximum wind speed 160 Km/Hr.
4. Finish : Hot dip galvanized to BS ISO 1461 (or as specified).
5. Accessories are made of Mild Steel Grade.
6. Shaft made of Steel Grade FE 430C (According to EN 10025).

# STEPPED POLES





# TUNNEL CONSTRUCTION





## TUNNEL CONSTRUCTION

ATOM STEEL LTD can efficiently and quickly provide hundreds of tunnel supports

from the smallest beams or other structural steel sections up to the largest. Unlike beams formed by presses, the beams rolled by ATOM STEEL LTD have minimal or no deformation in the flanges or web.



- Highway lining trolley is a special equipment that must be used in the secondary lining of the double track highway tunnel construction process. It is used for lining the inner wall of the tunnel. It has the functions of vertical mold and demoulding function, high surface finish of lining and fast lining speed.

The trolley widely used in highway, railway, water projects, hydraulic engineering, public projects, and defense industry projects.

- The Tunnel Trolley which consist of formwork assembly, traveling device, portal-frame assembly, Principal and master-slave traveling device, lateral hydraulic oil cylinder, lateral support jack and portal-frame support jack etc.





# TUNNEL CONSTRUCTION



Highway lining trolley is a special equipment that must be used in the secondary lining of the doubletrack highway tunnel construction process.

It is used for lining the inner wall of the tunnel. It has the functions of vertical mold and demoulding function, high surface finish of lining and fast lining speed.

The trolley widely used in highway, railway water projects, hydraulic engineering, public projects, and defense industry projects.

The Tunnel Trolley which consist of formwork assembly, traveling device, portal-frame assembly, principal and master-slave traveling device, lateral hydraulic oil cylinder, lateral support jack and portal-frame support jack etc.



# TUNNEL CONSTRUCTION





# TUNNEL CONSTRUCTION



Metal support arches are used in a wide range of applications and with many different soil conditions, offering the advantage of being resistance to compression and traction efforts with a high bending moment. This support technique is suitable for soil conditions that are very prone to subsidence due to the efforts caused by converging soils.

Cold curved beams are used to adapt to the excavation diameter, using the radii required to install them in parallel to the soil. Our entire manufacturing process, from design, bending, welding and dispatch, is certified by:

EN-1090 (CE marking) and governed according to the ISO9001 quality system.

ATOM STEEL LTD lattice girder system is totally surrounded by concrete. There are no unconsolidated areas, voids or fissures visible. It represents a complete homogenous composite structure, reduces ground settlement and prevents the ingress of water.

ATOM STEEL LTD lattice girder system has been tested and successfully installed in many tunnel projects.



# TUNNEL CONSTRUCTION



# STRUCTURAL STEEL DESIGN







# STRUCTURAL STEEL DESIGN

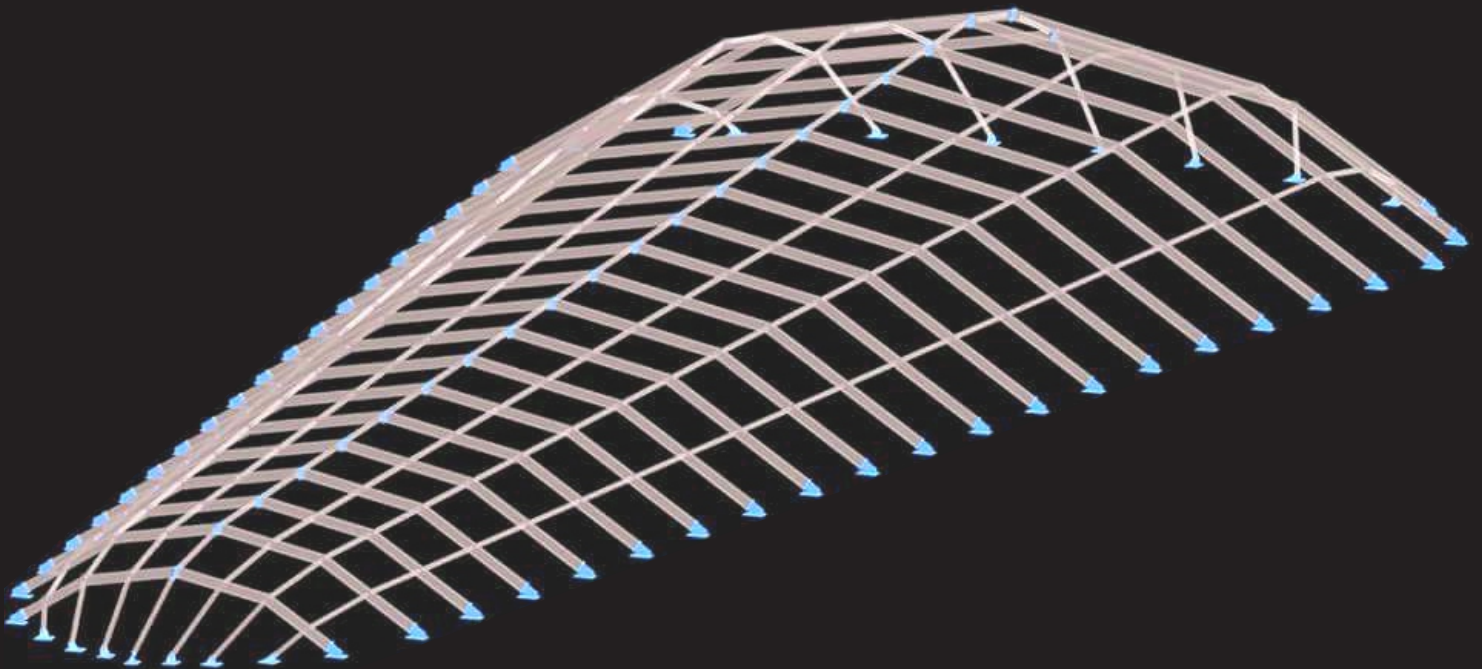



# STRUCTURAL STEEL DESIGN

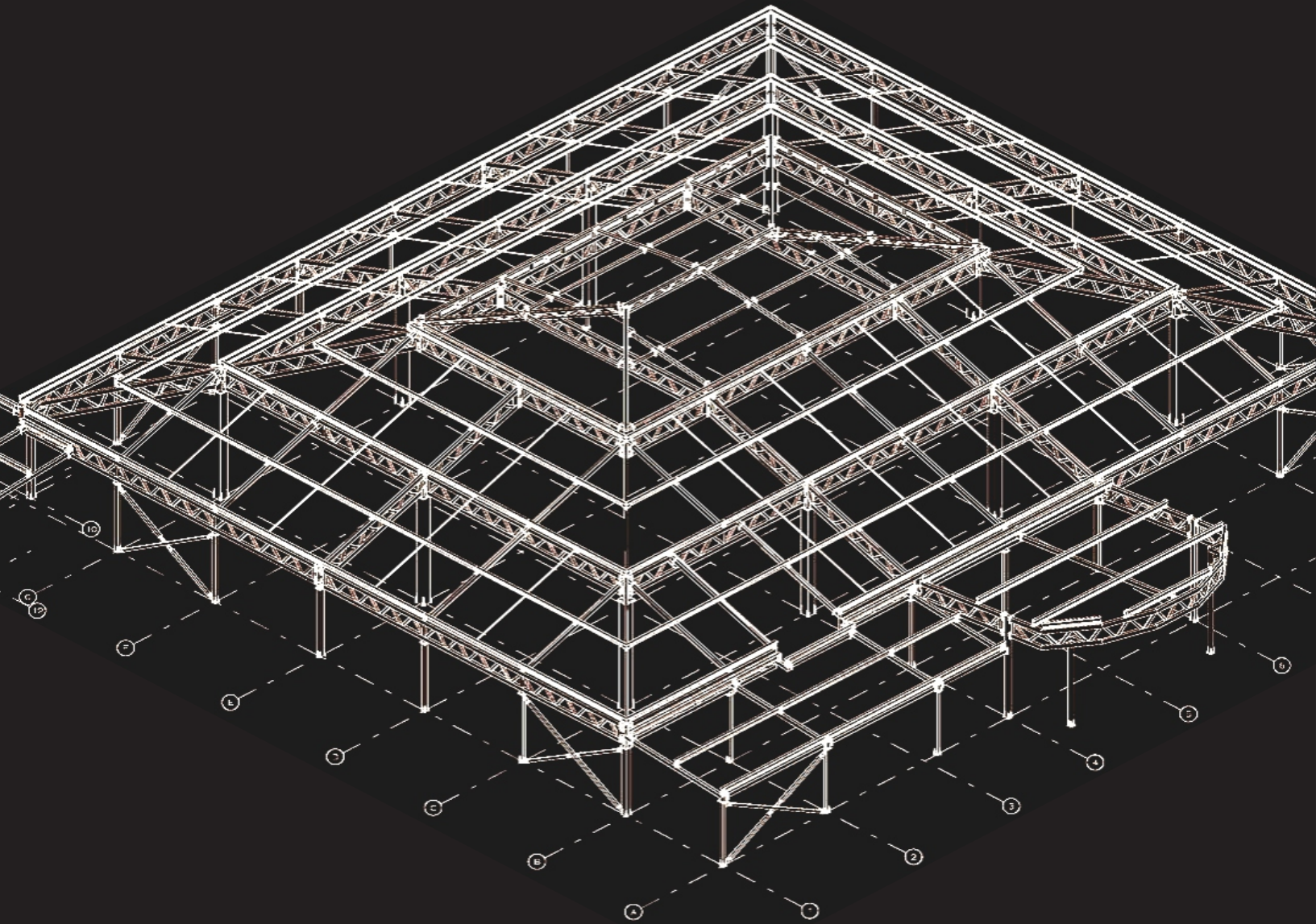



# STRUCTURAL STEEL DESIGN





# TANKS AND SILOS







# TANKS AND SILOS





### Vertical Steel Tank

Vertical steel tanks are used for storage of large quantities of oil and its derivatives, and can also be used for storage of other non-aggressive liquids.

### Oval Tank

The oval tank is intended for storage of small quantities of liquid fuels intended for central heating of residential buildings.

### Tank With Double Sheath

The horizontal double shielded tank is intended for the storage of light heating oils, which do not require preheating and are not under a pressure higher than 0.5 bar. It can be installed where increased safety, protection of land and environment from pollution is required. It can be installed as overground or underground.

### Lying Steel Tank

The horizontal steel tank is intended for storage of oil and its derivatives (except fuel oil), and can also be used for storage of other non-aggressive liquids. It can be installed as above ground or underground.

# TANKS AND SILOS





### Standing Tanks And Silos

Tanks and silos are made of various sizes, used to store various fluids or powdered substances in various industrial plants and other facilities.

### Tanks For Underground Installation

Tanks for liquefied petroleum gas – LPG are used for storage of liquefied petroleum gas (propane, butane or their mixtures) which serves as a propellant or for other purposes in the process industry.

Underground storage tanks for LPG are mainly used in stations for supplying motor vehicles with liquefied petroleum gas, in power plants or in propane and butane filling stations.

### Tanks For Overhead Installation

Tanks for liquefied petroleum gas – LPG (LPG) are used for storage of liquefied petroleum gas (propane, butane or their mixtures) which serves as a propellant or for other purposes in the process industry.

Overground storage tanks for LPG are mainly used in industrial plants, power plants or in propane and butane filling stations.

# BEAM WELDING





# BEAM WELDING

Atom Steel “Beam Welding Line” automatic, two or four head submerged arc-welding lines.

These machines are specifically designed for the manufacture of welded “T” and double “T” girder-beams with parallel or converging flange. They enable the welding to be carried out on items with the web located vertically and without any need for tacking. Tacking will only be required at the top in order to obtain the proper angle between the web and the flange.

The beam is fed into the machine and both sides of the beam are welded simultaneously. When double “T” beams are being manufactured, once the first flange has been welded, the beam is flipped over and fed back into the unit once again.

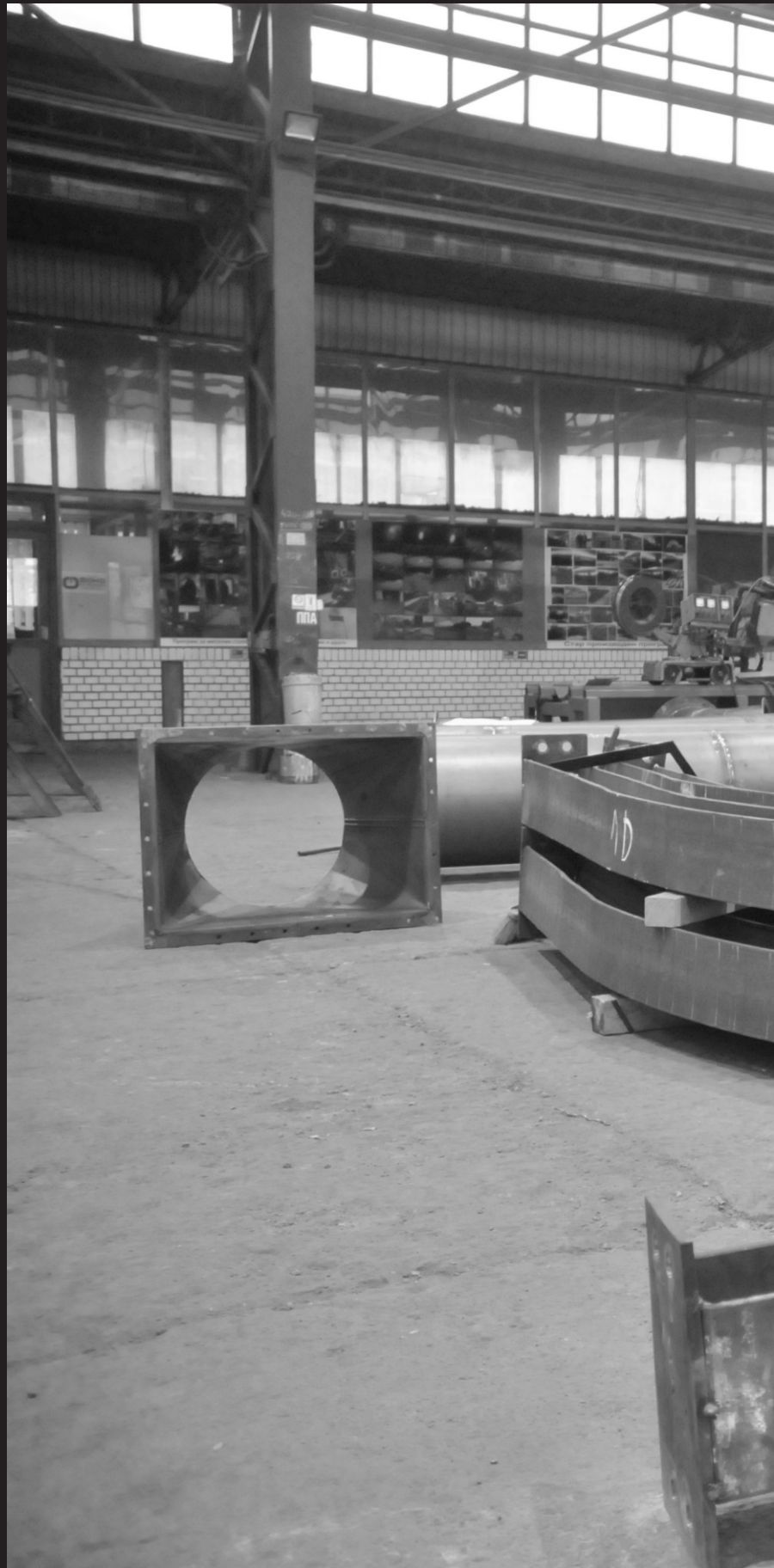





# CERTIFICATES





[www.atomsteel.eu](http://www.atomsteel.eu) | [info@atomsteel.eu](mailto:info@atomsteel.eu)



**ATOM STEEL**

